

Electronic Acknowledgement Receipt

EFS ID:	7980791
Application Number:	12832940
International Application Number:	
Confirmation Number:	5432
Title of Invention:	SYSTEM FOR OPERATING A VESSEL
First Named Inventor/Applicant Name:	Paul F. Rembach
Customer Number:	29637
Filer:	Wendy Buskop/Sarah Gernhart
Filer Authorized By:	Wendy Buskop
Attorney Docket Number:	1875.003
Receipt Date:	08-JUL-2010
Filing Date:	
Time Stamp:	21:35:50
Application Type:	Utility under 35 USC 111(a)

Payment information:

Submitted with Payment	yes
Payment Type	Deposit Account
Payment was successfully received in RAM	\$462
RAM confirmation Number	7884
Deposit Account	501313
Authorized User	

The Director of the USPTO is hereby authorized to charge indicated fees and credit any overpayment as follows:

Charge any Additional Fees required under 37 C.F.R. Section 1.16 (National application filing, search, and examination fees)

Charge any Additional Fees required under 37 C.F.R. Section 1.17 (Patent application and reexamination processing fees)

Charge any Additional Fees required under 37 C.F.R. Section 1.19 (Document supply fees)

Charge any Additional Fees required under 37 C.F.R. Section 1.20 (Post Issuance fees)

Charge any Additional Fees required under 37 C.F.R. Section 1.21 (Miscellaneous fees and charges)

File Listing:

Document Number	Document Description	File Name	File Size(Bytes)/ Message Digest	Multi Part /.zip	Pages (if appl.)
1	Application Data Sheet	1875-003_ADSFORM.pdf	1031535	no	5
			8f9d02fdda84c4bae50672c0dbe5822a355e36b1		

Warnings:

Information:

2	Oath or Declaration filed	1875-003_DECLARATIONOATH.pdf	363878	no	5
			845b885d379d16ee43ce50704b40f4a678c69159		

Warnings:

Information:

3	Nonpublication request from applicant.	1875-003_NONPUBREQUEST.pdf	234929	no	2
			228085d5f6e5a2ca37dfa4487b3bb9ede158ad10		

Warnings:

Information:

4	Information Disclosure Statement (IDS) Filed (SB/08)	1875-003_IDSFORM.pdf	612041	no	4
			eb69ffc87be6f4e63711ca902cbcc3b7e1a9312		

Warnings:

Information:

5		1875-003_PA_APPLICATION.pdf	293322	yes	23
			65f2977dee4184b63d8d8b22afd4e20b732fb012		

Multipart Description/PDF files in .zip description

Document Description	Start	End
Specification	1	17
Claims	18	22
Abstract	23	23

Warnings:

Information:

6	Drawings-only black and white line drawings	1875-003_DRAWINGS.pdf	434070	no	8
			6e91263af0a14295159b29d8912e426b3c9433d6		

Warnings:

Information:					
7	Fee Worksheet (PTO-875)	fee-info.pdf	33239	no	2
			6c782a6675a4c05a2a2734294ef3e50f4b1d7c7e		

Warnings:

Information:

Total Files Size (in bytes):	3003014
-------------------------------------	---------

This Acknowledgement Receipt evidences receipt on the noted date by the USPTO of the indicated documents, characterized by the applicant, and including page counts, where applicable. It serves as evidence of receipt similar to a Post Card, as described in MPEP 503.

New Applications Under 35 U.S.C. 111

If a new application is being filed and the application includes the necessary components for a filing date (see 37 CFR 1.53(b)-(d) and MPEP 506), a Filing Receipt (37 CFR 1.54) will be issued in due course and the date shown on this Acknowledgement Receipt will establish the filing date of the application.

National Stage of an International Application under 35 U.S.C. 371

If a timely submission to enter the national stage of an international application is compliant with the conditions of 35 U.S.C. 371 and other applicable requirements a Form PCT/DO/EO/903 indicating acceptance of the application as a national stage submission under 35 U.S.C. 371 will be issued in addition to the Filing Receipt, in due course.

New International Application Filed with the USPTO as a Receiving Office

If a new international application is being filed and the international application includes the necessary components for an international filing date (see PCT Article 11 and MPEP 1810), a Notification of the International Application Number and of the International Filing Date (Form PCT/RO/105) will be issued in due course, subject to prescriptions concerning national security, and the date shown on this Acknowledgement Receipt will establish the international filing date of the application.

Electronic Patent Application Fee Transmittal

Application Number:				
Filing Date:				
Title of Invention:	SYSTEM FOR OPERATING A VESSEL			
First Named Inventor/Applicant Name:	Paul F. Rembach			
Filer:	Wendy Buskop/Sarah Gernhart			
Attorney Docket Number:	1875.003			
Filed as Small Entity				
Utility under 35 USC 111(a) Filing Fees				
Description	Fee Code	Quantity	Amount	Sub-Total in USD(\$)
Basic Filing:				
Utility filing Fee (Electronic filing)	4011	1	82	82
Utility Search Fee	2111	1	270	270
Utility Examination Fee	2311	1	110	110
Pages:				
Claims:				
Miscellaneous-Filing:				
Petition:				
Patent-Appeals-and-Interference:				

Description	Fee Code	Quantity	Amount	Sub-Total in USD(\$)
Post-Allowance-and-Post-Issuance:				
Extension-of-Time:				
Miscellaneous:				
Total in USD (\$)				462

Under the Paperwork Reduction Act of 1995, no persons are required to respond to a collection of information unless it contains a valid OMB control number.

Application Data Sheet 37 CFR 1.76		Attorney Docket Number	1875.003
		Application Number	
Title of Invention	SYSTEM FOR OPERATING A VESSEL		
<p>The application data sheet is part of the provisional or nonprovisional application for which it is being submitted. The following form contains the bibliographic data arranged in a format specified by the United States Patent and Trademark Office as outlined in 37 CFR 1.76. This document may be completed electronically and submitted to the Office in electronic format using the Electronic Filing System (EFS) or the document may be printed and included in a paper filed application.</p>			

Secrecy Order 37 CFR 5.2

Portions or all of the application associated with this Application Data Sheet may fall under a Secrecy Order pursuant to 37 CFR 5.2 (Paper filers only. Applications that fall under Secrecy Order may not be filed electronically.)

Applicant Information:

Applicant 1					
Applicant Authority <input checked="" type="radio"/> Inventor		<input type="radio"/> Legal Representative under 35 U.S.C. 117		<input type="radio"/> Party of Interest under 35 U.S.C. 118	
Prefix	Given Name	Middle Name	Family Name	Suffix	
	Paul	F.	Rembach		
Residence Information (Select One) <input checked="" type="radio"/> US Residency <input type="radio"/> Non US Residency <input type="radio"/> Active US Military Service					
City	Houston	State/Province	TX	Country of Residence	US
Citizenship under 37 CFR 1.41(b)		US			
Mailing Address of Applicant:					
Address 1		11503 Dakar Drive			
Address 2					
City	Houston	State/Province	TX		
Postal Code	77065	Country	US		
Applicant 2					
Applicant Authority <input checked="" type="radio"/> Inventor		<input type="radio"/> Legal Representative under 35 U.S.C. 117		<input type="radio"/> Party of Interest under 35 U.S.C. 118	
Prefix	Given Name	Middle Name	Family Name	Suffix	
	Greg		Castleman		
Residence Information (Select One) <input checked="" type="radio"/> US Residency <input type="radio"/> Non US Residency <input type="radio"/> Active US Military Service					
City	Kemah	State/Province	TX	Country of Residence	US
Citizenship under 37 CFR 1.41(b)		US			
Mailing Address of Applicant:					
Address 1		11503 Dakar Drive			
Address 2					
City	Houston	State/Province	TX		
Postal Code	77065	Country	US		
<p>All Inventors Must Be Listed - Additional Inventor Information blocks may be generated within this form by selecting the Add button.</p> <div style="text-align: right;"><input type="button" value="Add"/></div>					

Correspondence Information:

Enter either Customer Number or complete the Correspondence Information section below. For further information see 37 CFR 1.33(a).

An Address is being provided for the correspondence information of this application.

Under the Paperwork Reduction Act of 1995, no persons are required to respond to a collection of information unless it contains a valid OMB control number.

Application Data Sheet 37 CFR 1.76		Attorney Docket Number	1875.003	
		Application Number		
Title of Invention	SYSTEM FOR OPERATING A VESSEL			
Customer Number	29637			
Email Address	sarah.gernhart@buskoplaw.com		<input type="button" value="Add Email"/>	<input type="button" value="Remove Email"/>

Application Information:

Title of the Invention	SYSTEM FOR OPERATING A VESSEL			
Attorney Docket Number	1875.003	Small Entity Status Claimed	<input checked="" type="checkbox"/>	
Application Type	Nonprovisional			
Subject Matter	Utility			
Suggested Class (if any)		Sub Class (if any)		
Suggested Technology Center (if any)				
Total Number of Drawing Sheets (if any)	8	Suggested Figure for Publication (if any)		

Publication Information:

<input type="checkbox"/> Request Early Publication (Fee required at time of Request 37 CFR 1.219)	
<input checked="" type="checkbox"/>	Request Not to Publish. I hereby request that the attached application not be published under 35 U.S.C. 122(b) and certify that the invention disclosed in the attached application has not and will not be the subject of an application filed in another country, or under a multilateral international agreement, that requires publication at eighteen months after filing.

Representative Information:

<p>Representative information should be provided for all practitioners having a power of attorney in the application. Providing this information in the Application Data Sheet does not constitute a power of attorney in the application (see 37 CFR 1.32). Enter either Customer Number or complete the Representative Name section below. If both sections are completed the Customer Number will be used for the Representative Information during processing.</p>			
Please Select One:	<input checked="" type="radio"/> Customer Number	<input type="radio"/> US Patent Practitioner	<input type="radio"/> Limited Recognition (37 CFR 11.9)
Customer Number	29637		

Domestic Benefit/National Stage Information:

This section allows for the applicant to either claim benefit under 35 U.S.C. 119(e), 120, 121, or 365(c) or indicate National Stage entry from a PCT application. Providing this information in the application data sheet constitutes the specific reference required by 35 U.S.C. 119(e) or 120, and 37 CFR 1.78(a)(2) or CFR 1.78(a)(4), and need not otherwise be made part of the specification.			
Prior Application Status	Pending	<input type="button" value="Remove"/>	
Application Number	Continuity Type	Prior Application Number	Filing Date (YYYY-MM-DD)
	Continuation in part of	12313732	2008-11-24
Prior Application Status	Expired	<input type="button" value="Remove"/>	
Application Number	Continuity Type	Prior Application Number	Filing Date (YYYY-MM-DD)
12313732	non provisional of	61004397	2007-11-25

Under the Paperwork Reduction Act of 1995, no persons are required to respond to a collection of information unless it contains a valid OMB control number.

Application Data Sheet 37 CFR 1.76	Attorney Docket Number	1875.003
	Application Number	
Title of Invention	SYSTEM FOR OPERATING A VESSEL	

Additional Domestic Benefit/National Stage Data may be generated within this form by selecting the **Add** button.

Foreign Priority Information:

This section allows for the applicant to claim benefit of foreign priority and to identify any prior foreign application for which priority is not claimed. Providing this information in the application data sheet constitutes the claim for priority as required by 35 U.S.C. 119(b) and 37 CFR 1.55(a).

			<input type="button" value="Remove"/>
Application Number	Country ¹	Parent Filing Date (YYYY-MM-DD)	Priority Claimed
			<input type="radio"/> Yes <input checked="" type="radio"/> No

Additional Foreign Priority Data may be generated within this form by selecting the **Add** button.

Assignee Information:

Providing this information in the application data sheet does not substitute for compliance with any requirement of part 3 of Title 37 of the CFR to have an assignment recorded in the Office.

Assignee 1

If the Assignee is an Organization check here.

Prefix	Given Name	Middle Name	Family Name	Suffix

Mailing Address Information:

Address 1			
Address 2			
City		State/Province	
Country ¹		Postal Code	
Phone Number		Fax Number	
Email Address			

Additional Assignee Data may be generated within this form by selecting the **Add** button.

Signature:

A signature of the applicant or representative is required in accordance with 37 CFR 1.33 and 10.18. Please see 37 CFR 1.4(d) for the form of the signature.

Signature	/WBUSKOP/	Date (YYYY-MM-DD)	2010-07-08
First Name	Wendy	Last Name	Buskop
		Registration Number	32202

Under the Paperwork Reduction Act of 1995, no persons are required to respond to a collection of information unless it contains a valid OMB control number.

Application Data Sheet 37 CFR 1.76	Attorney Docket Number	1875.003
	Application Number	
Title of Invention	SYSTEM FOR OPERATING A VESSEL	

This collection of information is required by 37 CFR 1.76. The information is required to obtain or retain a benefit by the public which is to file (and by the USPTO to process) an application. Confidentiality is governed by 35 U.S.C. 122 and 37 CFR 1.14. This collection is estimated to take 23 minutes to complete, including gathering, preparing, and submitting the completed application data sheet form to the USPTO. Time will vary depending upon the individual case. Any comments on the amount of time you require to complete this form and/or suggestions for reducing this burden, should be sent to the Chief Information Officer, U.S. Patent and Trademark Office, U.S. Department of Commerce, P.O. Box 1450, Alexandria, VA 22313-1450. DO NOT SEND FEES OR COMPLETED FORMS TO THIS ADDRESS. **SEND TO: Commissioner for Patents, P.O. Box 1450, Alexandria, VA 22313-1450.**

Privacy Act Statement

The Privacy Act of 1974 (P.L. 93-579) requires that you be given certain information in connection with your submission of the attached form related to a patent application or patent. Accordingly, pursuant to the requirements of the Act, please be advised that: (1) the general authority for the collection of this information is 35 U.S.C. 2(b)(2); (2) furnishing of the information solicited is voluntary; and (3) the principal purpose for which the information is used by the U.S. Patent and Trademark Office is to process and/or examine your submission related to a patent application or patent. If you do not furnish the requested information, the U.S. Patent and Trademark Office may not be able to process and/or examine your submission, which may result in termination of proceedings or abandonment of the application or expiration of the patent.

The information provided by you in this form will be subject to the following routine uses:

1. The information on this form will be treated confidentially to the extent allowed under the Freedom of Information Act (5 U.S.C. 552) and the Privacy Act (5 U.S.C. 552a). Records from this system of records may be disclosed to the Department of Justice to determine whether the Freedom of Information Act requires disclosure of these records.
2. A record from this system of records may be disclosed, as a routine use, in the course of presenting evidence to a court, magistrate, or administrative tribunal, including disclosures to opposing counsel in the course of settlement negotiations.
3. A record in this system of records may be disclosed, as a routine use, to a Member of Congress submitting a request involving an individual, to whom the record pertains, when the individual has requested assistance from the Member with respect to the subject matter of the record.
4. A record in this system of records may be disclosed, as a routine use, to a contractor of the Agency having need for the information in order to perform a contract. Recipients of information shall be required to comply with the requirements of the Privacy Act of 1974, as amended, pursuant to 5 U.S.C. 552a(m).
5. A record related to an International Application filed under the Patent Cooperation Treaty in this system of records may be disclosed, as a routine use, to the International Bureau of the World Intellectual Property Organization, pursuant to the Patent Cooperation Treaty.
6. A record in this system of records may be disclosed, as a routine use, to another federal agency for purposes of National Security review (35 U.S.C. 181) and for review pursuant to the Atomic Energy Act (42 U.S.C. 218(c)).
7. A record from this system of records may be disclosed, as a routine use, to the Administrator, General Services, or his/her designee, during an inspection of records conducted by GSA as part of that agency's responsibility to recommend improvements in records management practices and programs, under authority of 44 U.S.C. 2904 and 2906. Such disclosure shall be made in accordance with the GSA regulations governing inspection of records for this purpose, and any other relevant (i.e., GSA or Commerce) directive. Such disclosure shall not be used to make determinations about individuals.
8. A record from this system of records may be disclosed, as a routine use, to the public after either publication of the application pursuant to 35 U.S.C. 122(b) or issuance of a patent pursuant to 35 U.S.C. 151. Further, a record may be disclosed, subject to the limitations of 37 CFR 1.14, as a routine use, to the public if the record was filed in an application which became abandoned or in which the proceedings were terminated and which application is referenced by either a published application, an application open to public inspections or an issued patent.
9. A record from this system of records may be disclosed, as a routine use, to a Federal, State, or local law enforcement agency, if the USPTO becomes aware of a violation or potential violation of law or regulation.

Under the Paperwork Reduction Act of 1995, no persons are required to respond to a collection of information unless it contains a valid OMB control number.

DECLARATION FOR UTILITY OR DESIGN PATENT APPLICATION (37 CFR 1.63) <input checked="" type="checkbox"/> Declaration Submitted With Initial Filing OR <input type="checkbox"/> Declaration Submitted After Initial Filing (surcharge (37 CFR 1.16(f) required))	Attorney Docket Number	1875.003
	First Named Inventor	PAUL F. REMBACH et al.
	<i>COMPLETE IF KNOWN</i>	
	Application Number	
	Filing Date	
	Art Unit	
Examiner Name		

I hereby declare that: (1) Each inventor's residence, mailing address, and citizenship are as stated below next to their name; and (2) I believe the inventor(s) named below to be the original and first inventor(s) of the subject matter which is claimed and for which a patent is sought on the invention titled:

SYSTEM FOR OPERATING A VESSEL

(Title of the Invention)

the application of which

is attached hereto

OR

was filed on (MM/DD/YYYY) _____ as United States Application Number or PCT International Application Number _____ and was amended on (MM/DD/YYYY) _____ (if applicable).

I hereby state that I have reviewed and understand the contents of the above identified application, including the claims, as amended by any amendment specifically referred to above.

I acknowledge the duty to disclose information which is material to patentability as defined in 37 CFR 1.56, including for continuation-in-part applications, material information which became available between the filing date of the prior application and the national or PCT international filing date of the continuation-in-part application.

Authorization To Permit Access To Application by Participating Offices

If checked, the undersigned hereby grants the USPTO authority to provide the European Patent Office (EPO), the Japan Patent Office (JPO), the Korean Intellectual Property Office (KIPO), the World Intellectual Property Office (WIPO), and any other intellectual property offices in which a foreign application claiming priority to the above-identified patent application is filed access to the above-identified patent application. See 37 CFR 1.14(c) and (h). This box should not be checked if the applicant does not wish the EPO, JPO, KIPO, WIPO, or other intellectual property office in which a foreign application claiming priority to the above-identified patent application is filed to have access to the above-identified patent application.

In accordance with 37 CFR 1.14(h)(3), access will be provided to a copy of the above-identified patent application with respect to: 1) the above-identified patent application-as-filed; 2) any foreign application to which the above-identified patent application claims priority under 35 U.S.C. 119(a)-(d) if a copy of the foreign application that satisfies the certified copy requirement of 37 CFR 1.55 has been filed in the above-identified patent application; and 3) any U.S. application-as-filed from which benefit is sought in the above-identified patent application.

In accordance with 37 CFR 1.14(c), access may be provided to information concerning the date of filing the Authorization to Permit Access to Application by Participating Offices.

Under the Paperwork Reduction Act of 1995, no persons are required to respond to a collection of information unless it contains a valid OMB control number.

DECLARATION — Utility or Design Patent Application

Claim of Foreign Priority Benefits

I hereby claim foreign priority benefits under 35 U.S.C. 119(a)-(d) or (f), or 365(b) of any foreign application(s) for patent, inventor's or plant breeder's rights certificate(s), or 365(a) of any PCT international application which designated at least one country other than the United States of America, listed below and have also identified below, by checking the box, any foreign application for patent, inventor's or plant breeder's rights certificate(s), or any PCT international application having a filing date before that of the application on which priority is claimed.

Prior Foreign Application Number(s)	Country	Foreign Filing Date (MM/DD/YYYY)	Priority Not Claimed	Certified Copy Attached?	
				YES	NO
			<input type="checkbox"/>	<input type="checkbox"/>	<input type="checkbox"/>
			<input type="checkbox"/>	<input type="checkbox"/>	<input type="checkbox"/>
			<input type="checkbox"/>	<input type="checkbox"/>	<input type="checkbox"/>
			<input type="checkbox"/>	<input type="checkbox"/>	<input type="checkbox"/>

Additional foreign application number(s) are listed on a supplemental priority data sheet PTO/SB/02B attached hereto.

Under the Paperwork Reduction Act of 1995, no persons are required to respond to a collection of information unless it contains a valid OMB control number.

DECLARATION — Utility or Design Patent Application

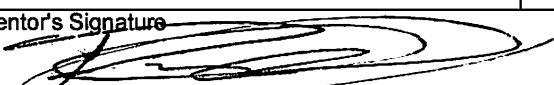
Direct all correspondence to:	<input checked="" type="checkbox"/>	The address associated with Customer Number:	<input type="text" value="29637"/>	OR	<input type="checkbox"/>	Correspondence address below
Name						
Address						
City			State		Zip	
Country		Telephone		Email		
<p align="center">WARNING:</p> <p>Petitioner/applicant is cautioned to avoid submitting personal information in documents filed in a patent application that may contribute to identity theft. Personal information such as social security numbers, bank account numbers, or credit card numbers (other than a check or credit card authorization form PTO-2038 submitted for payment purposes) is never required by the USPTO to support a petition or an application. If this type of personal information is included in documents submitted to the USPTO, petitioners/applicants should consider redacting such personal information from the documents before submitting them to the USPTO. Petitioner/applicant is advised that the record of a patent application is available to the public after publication of the application (unless a non-publication request in compliance with 37 CFR 1.213(a) is made in the application) or issuance of a patent. Furthermore, the record from an abandoned application may also be available to the public if the application is referenced in a published application or an issued patent (see 37 CFR 1.14). Checks and credit card authorization forms PTO-2038 submitted for payment purposes are not retained in the application file and therefore are not publicly available. Petitioner/applicant is advised that documents which form the record of a patent application (such as the PTO/SB/01) are placed into the Privacy Act system of records DEPARTMENT OF COMMERCE, COMMERCE-PAT-7, System name: <i>Patent Application Files</i>. Documents not retained in an application file (such as the PTO-2038) are placed into the Privacy Act system of COMMERCE/PAT-TM-10, System name: <i>Deposit Accounts and Electronic Funds Transfer Profiles</i>.</p> <p>I hereby declare that all statements made herein of my own knowledge are true and that all statements made on information and belief are believed to be true; and further that these statements were made with the knowledge that willful false statements and the like so made are punishable by fine or imprisonment, or both, under 18 U.S.C. 1001 and that such willful false statements may jeopardize the validity of the application or any patent issued thereon.</p>						
NAME OF SOLE OR FIRST INVENTOR:			<input type="checkbox"/> A petition has been filed for this unsigned inventor			
Given Name (first and middle [if any])			Family Name or Surname			
Paul F.			Rembach			
Inventor's Signature					Date	
					July 6, 2010	
Residence: City		State		Country		Citizenship
Houston		TX		US		US
Mailing Address						
11503 Dakar Drive						
City		State		Zip		Country
Houston		TX		77065		US
<input checked="" type="checkbox"/> Additional inventors or a legal representative are being named on the <u>1</u> supplemental sheet(s) PTO/SB/02A or 02LR attached hereto						

Under the Paperwork Reduction Act of 1995, no persons are required to respond to a collection of information unless it contains a valid OMB control number.

DECLARATION**ADDITIONAL INVENTOR(S)**
Supplemental SheetPage ⁴ of **5**

Name of Additional Joint Inventor, if any:		<input type="checkbox"/> A petition has been filed for this unsigned inventor	
Given Name (first and middle (if any))		Family Name or Surname	
Greg		Castleman	
Inventor's Signature <i>Greg Castle</i>		Date 7/6/10	
Kemah Residence: City	TX State	US Country	US Citizenship
11503 Dakar Drive			
Mailing Address			
Houston City	TX State	77065 Zip	US Country
Name of Additional Joint Inventor, if any:		<input type="checkbox"/> A petition has been filed for this unsigned inventor	
Given Name (first and middle (if any))		Family Name or Surname	
Inventor's Signature		Date	
Residence: City	State	Country	Citizenship
Mailing Address			
City	State	Zip	Country
Name of Additional Joint Inventor, if any:		<input type="checkbox"/> A petition has been filed for this unsigned inventor	
Given Name (first and middle (if any))		Family Name or Surname	
Inventor's Signature		Date	
Residence: City	State	Country	Citizenship
Mailing Address			
City	State	Zip	Country

This collection of information is required by 35 U.S.C. 115 and 37 CFR 1.63. The information is required to obtain or retain a benefit by the public which is to file (and by the USPTO to process) an application. Confidentiality is governed by 35 U.S.C. 122 and 37 CFR 1.11 and 1.14. This collection is estimated to take 21 minutes to complete, including gathering, preparing, and submitting the completed application form to the USPTO. Time will vary depending upon the individual case. Any comments on the amount of time you require to complete this form and/or suggestions for reducing this burden, should be sent to the Chief Information Officer, U.S. Patent and Trademark Office, U.S. Department of Commerce, P.O. Box 1450, Alexandria, VA 22313-1450. DO NOT SEND FEES OR COMPLETED FORMS TO THIS ADDRESS. SEND TO: Commissioner for Patents, P.O. Box 1450, Alexandria, VA 22313-1450.

If you need assistance in completing the form, call 1-800-PTO-9199 (1-800-786-9199) and select option 2.

Privacy Act Statement

The Privacy Act of 1974 (P.L. 93-579) requires that you be given certain information in connection with your submission of the attached form related to a patent application or patent. Accordingly, pursuant to the requirements of the Act, please be advised that: (1) the general authority for the collection of this information is 35 U.S.C. 2(b)(2); (2) furnishing of the information solicited is voluntary; and (3) the principal purpose for which the information is used by the U.S. Patent and Trademark Office is to process and/or examine your submission related to a patent application or patent. If you do not furnish the requested information, the U.S. Patent and Trademark Office may not be able to process and/or examine your submission, which may result in termination of proceedings or abandonment of the application or expiration of the patent.

The information provided by you in this form will be subject to the following routine uses:

1. The information on this form will be treated confidentially to the extent allowed under the Freedom of Information Act (5 U.S.C. 552) and the Privacy Act (5 U.S.C. 552a). Records from this system of records may be disclosed to the Department of Justice to determine whether disclosure of these records is required by the Freedom of Information Act.
2. A record from this system of records may be disclosed, as a routine use, in the course of presenting evidence to a court, magistrate, or administrative tribunal, including disclosures to opposing counsel in the course of settlement negotiations.
3. A record in this system of records may be disclosed, as a routine use, to a Member of Congress submitting a request involving an individual, to whom the record pertains, when the individual has requested assistance from the Member with respect to the subject matter of the record.
4. A record in this system of records may be disclosed, as a routine use, to a contractor of the Agency having need for the information in order to perform a contract. Recipients of information shall be required to comply with the requirements of the Privacy Act of 1974, as amended, pursuant to 5 U.S.C. 552a(m).
5. A record related to an International Application filed under the Patent Cooperation Treaty in this system of records may be disclosed, as a routine use, to the International Bureau of the World Intellectual Property Organization, pursuant to the Patent Cooperation Treaty.
6. A record in this system of records may be disclosed, as a routine use, to another federal agency for purposes of National Security review (35 U.S.C. 181) and for review pursuant to the Atomic Energy Act (42 U.S.C. 218(c)).
7. A record from this system of records may be disclosed, as a routine use, to the Administrator, General Services, or his/her designee, during an inspection of records conducted by GSA as part of that agency's responsibility to recommend improvements in records management practices and programs, under authority of 44 U.S.C. 2904 and 2906. Such disclosure shall be made in accordance with the GSA regulations governing inspection of records for this purpose, and any other relevant (i.e., GSA or Commerce) directive. Such disclosure shall not be used to make determinations about individuals.
8. A record from this system of records may be disclosed, as a routine use, to the public after either publication of the application pursuant to 35 U.S.C. 122(b) or issuance of a patent pursuant to 35 U.S.C. 151. Further, a record may be disclosed, subject to the limitations of 37 CFR 1.14, as a routine use, to the public if the record was filed in an application which became abandoned or in which the proceedings were terminated and which application is referenced by either a published application, an application open to public inspection or an issued patent.
9. A record from this system of records may be disclosed, as a routine use, to a Federal, State, or local law enforcement agency, if the USPTO becomes aware of a violation or potential violation of law or regulation.

Under the Paperwork Reduction Act of 1995, no persons are required to respond to a collection of information unless it displays a valid OMB control number.

NONPUBLICATION REQUEST UNDER 35 U.S.C. 122(b)(2)(B)(i)	First Named Inventor		Paul F. Rembach et al.
	Title	SYSTEM FOR OPERATING A VESSEL	
	Attorney Docket Number		1875.003

I hereby certify that the invention disclosed in the attached application **has not and will not be** the subject of an application filed in another country, or under a multilateral international agreement, that requires publication at eighteen months after filing.

I hereby request that the attached application not be published under 35 U.S.C. 122(b).

/WBUSKOP/

July 08, 2010

Signature

Date

Wendy Buskop

32,202

Typed or printed name

Registration Number, if applicable

713-275-3400

Telephone Number

This request must be signed in compliance with 37 CFR 1.33(b) and submitted with the application **upon filing**.

Applicant may rescind this nonpublication request at any time. If applicant rescinds a request that an application not be published under 35 U.S.C. 122(b), the application will be scheduled for publication at eighteen months from the earliest claimed filing date for which a benefit is claimed.

If applicant subsequently files an application directed to the invention disclosed in the attached application in another country, or under a multilateral international agreement, that requires publication of applications eighteen months after filing, the applicant **must** notify the United States Patent and Trademark Office of such filing within forty-five (45) days after the date of the filing of such foreign or international application. **Failure to do so will result in abandonment of this application (35 U.S.C. 122(b)(2)(B)(iii)).**

This collection of information is required by 37 CFR 1.213(a). The information is required to obtain or retain a benefit by the public which is to file (and by the USPTO to process) an application. Confidentiality is governed by 35 U.S.C. 122 and 37 CFR 1.11 and 1.14. This collection is estimated to take 6 minutes to complete, including gathering, preparing, and submitting the completed application form to the USPTO. Time will vary depending upon the individual case. Any comments on the amount of time you require to complete this form and/or suggestions for reducing this burden, should be sent to the Chief Information Officer, U.S. Patent and Trademark Office, U.S. Department of Commerce, P.O. Box 1450, Alexandria, VA 22313-1450. DO NOT SEND FEES OR COMPLETED FORMS TO THIS ADDRESS. **SEND TO: Commissioner for Patents, P.O. Box 1450, Alexandria, VA 22313-1450.**

Privacy Act Statement

The **Privacy Act of 1974 (P.L. 93-579)** requires that you be given certain information in connection with your submission of the attached form related to a patent application or patent. Accordingly, pursuant to the requirements of the Act, please be advised that: (1) the general authority for the collection of this information is 35 U.S.C. 2(b)(2); (2) furnishing of the information solicited is voluntary; and (3) the principal purpose for which the information is used by the U.S. Patent and Trademark Office is to process and/or examine your submission related to a patent application or patent. If you do not furnish the requested information, the U.S. Patent and Trademark Office may not be able to process and/or examine your submission, which may result in termination of proceedings or abandonment of the application or expiration of the patent.

The information provided by you in this form will be subject to the following routine uses:

1. The information on this form will be treated confidentially to the extent allowed under the Freedom of Information Act (5 U.S.C. 552) and the Privacy Act (5 U.S.C. 552a). Records from this system of records may be disclosed to the Department of Justice to determine whether disclosure of these records is required by the Freedom of Information Act.
2. A record from this system of records may be disclosed, as a routine use, in the course of presenting evidence to a court, magistrate, or administrative tribunal, including disclosures to opposing counsel in the course of settlement negotiations.
3. A record in this system of records may be disclosed, as a routine use, to a Member of Congress submitting a request involving an individual, to whom the record pertains, when the individual has requested assistance from the Member with respect to the subject matter of the record.
4. A record in this system of records may be disclosed, as a routine use, to a contractor of the Agency having need for the information in order to perform a contract. Recipients of information shall be required to comply with the requirements of the Privacy Act of 1974, as amended, pursuant to 5 U.S.C. 552a(m).
5. A record related to an International Application filed under the Patent Cooperation Treaty in this system of records may be disclosed, as a routine use, to the International Bureau of the World Intellectual Property Organization, pursuant to the Patent Cooperation Treaty.
6. A record in this system of records may be disclosed, as a routine use, to another federal agency for purposes of National Security review (35 U.S.C. 181) and for review pursuant to the Atomic Energy Act (42 U.S.C. 218(c)).
7. A record from this system of records may be disclosed, as a routine use, to the Administrator, General Services, or his/her designee, during an inspection of records conducted by GSA as part of that agency's responsibility to recommend improvements in records management practices and programs, under authority of 44 U.S.C. 2904 and 2906. Such disclosure shall be made in accordance with the GSA regulations governing inspection of records for this purpose, and any other relevant (*i.e.*, GSA or Commerce) directive. Such disclosure shall not be used to make determinations about individuals.
8. A record from this system of records may be disclosed, as a routine use, to the public after either publication of the application pursuant to 35 U.S.C. 122(b) or issuance of a patent pursuant to 35 U.S.C. 151. Further, a record may be disclosed, subject to the limitations of 37 CFR 1.14, as a routine use, to the public if the record was filed in an application which became abandoned or in which the proceedings were terminated and which application is referenced by either a published application, an application open to public inspection or an issued patent.
9. A record from this system of records may be disclosed, as a routine use, to a Federal, State, or local law enforcement agency, if the USPTO becomes aware of a violation or potential violation of law or regulation.

INFORMATION DISCLOSURE STATEMENT BY APPLICANT (Not for submission under 37 CFR 1.99)	Application Number		
	Filing Date		
	First Named Inventor	Paul F. Rembach et al.	
	Art Unit		
	Examiner Name		
	Attorney Docket Number	1874.003	

U.S.PATENTS

Examiner Initial*	Cite No	Patent Number	Kind Code ¹	Issue Date	Name of Patentee or Applicant of cited Document	Pages, Columns, Lines where Relevant Passages or Relevant Figures Appear
	1	6132267		2000-10-17	Campbell, James Stewart	
	2	6000353		1999-12-14	De Leu, Douglas F.	
	3	5131875		1992-07-21	Lee, Warren D.	

If you wish to add additional U.S. Patent citation information please click the Add button.

U.S.PATENT APPLICATION PUBLICATIONS

Examiner Initial*	Cite No	Publication Number	Kind Code ¹	Publication Date	Name of Patentee or Applicant of cited Document	Pages, Columns, Lines where Relevant Passages or Relevant Figures Appear
	1	20080064273	A1	2008-03-13	Mizokawa, Takashi	
	2	20040242088	A1	2004-12-02	McCann, John	

If you wish to add additional U.S. Published Application citation information please click the Add button.

FOREIGN PATENT DOCUMENTS

Examiner Initial*	Cite No	Foreign Document Number ³	Country Code ²ⁱ	Kind Code ⁴	Publication Date	Name of Patentee or Applicant of cited Document	Pages, Columns, Lines where Relevant Passages or Relevant Figures Appear	T ⁵
-------------------	---------	--------------------------------------	----------------------------	------------------------	------------------	---	--	----------------

**INFORMATION DISCLOSURE
STATEMENT BY APPLICANT**
(Not for submission under 37 CFR 1.99)

Application Number		
Filing Date		
First Named Inventor	Paul F. Rembach et al.	
Art Unit		
Examiner Name		
Attorney Docket Number	1874.003	

	1								<input type="checkbox"/>
--	---	--	--	--	--	--	--	--	--------------------------

If you wish to add additional Foreign Patent Document citation information please click the Add button

NON-PATENT LITERATURE DOCUMENTS

Examiner Initials*	Cite No	Include name of the author (in CAPITAL LETTERS), title of the article (when appropriate), title of the item (book, magazine, journal, serial, symposium, catalog, etc), date, pages(s), volume-issue number(s), publisher, city and/or country where published.	T ⁵
	1		<input type="checkbox"/>

If you wish to add additional non-patent literature document citation information please click the Add button

EXAMINER SIGNATURE

Examiner Signature		Date Considered	
--------------------	--	-----------------	--

*EXAMINER: Initial if reference considered, whether or not citation is in conformance with MPEP 609. Draw line through a citation if not in conformance and not considered. Include copy of this form with next communication to applicant.

¹ See Kind Codes of USPTO Patent Documents at www.USPTO.GOV or MPEP 901.04. ² Enter office that issued the document, by the two-letter code (WIPO Standard ST.3). ³ For Japanese patent documents, the indication of the year of the reign of the Emperor must precede the serial number of the patent document. ⁴ Kind of document by the appropriate symbols as indicated on the document under WIPO Standard ST.16 if possible. ⁵ Applicant is to place a check mark here if English language translation is attached.

**INFORMATION DISCLOSURE
STATEMENT BY APPLICANT**
(Not for submission under 37 CFR 1.99)

Application Number	
Filing Date	
First Named Inventor	Paul F. Rembach et al.
Art Unit	
Examiner Name	
Attorney Docket Number	1874.003

CERTIFICATION STATEMENT

Please see 37 CFR 1.97 and 1.98 to make the appropriate selection(s):

That each item of information contained in the information disclosure statement was first cited in any communication from a foreign patent office in a counterpart foreign application not more than three months prior to the filing of the information disclosure statement. See 37 CFR 1.97(e)(1).

OR

That no item of information contained in the information disclosure statement was cited in a communication from a foreign patent office in a counterpart foreign application, and, to the knowledge of the person signing the certification after making reasonable inquiry, no item of information contained in the information disclosure statement was known to any individual designated in 37 CFR 1.56(c) more than three months prior to the filing of the information disclosure statement. See 37 CFR 1.97(e)(2).

See attached certification statement.

Fee set forth in 37 CFR 1.17 (p) has been submitted herewith.

None

SIGNATURE

A signature of the applicant or representative is required in accordance with CFR 1.33, 10.18. Please see CFR 1.4(d) for the form of the signature.

Signature	/WBUSKOP/	Date (YYYY-MM-DD)	2010-07-08
Name/Print	Wendy Buskop	Registration Number	32202

This collection of information is required by 37 CFR 1.97 and 1.98. The information is required to obtain or retain a benefit by the public which is to file (and by the USPTO to process) an application. Confidentiality is governed by 35 U.S.C. 122 and 37 CFR 1.14. This collection is estimated to take 1 hour to complete, including gathering, preparing and submitting the completed application form to the USPTO. Time will vary depending upon the individual case. Any comments on the amount of time you require to complete this form and/or suggestions for reducing this burden, should be sent to the Chief Information Officer, U.S. Patent and Trademark Office, U.S. Department of Commerce, P.O. Box 1450, Alexandria, VA 22313-1450. **DO NOT SEND FEES OR COMPLETED FORMS TO THIS ADDRESS. SEND TO: Commissioner for Patents, P.O. Box 1450, Alexandria, VA 22313-1450.**

Privacy Act Statement

The Privacy Act of 1974 (P.L. 93-579) requires that you be given certain information in connection with your submission of the attached form related to a patent application or patent. Accordingly, pursuant to the requirements of the Act, please be advised that: (1) the general authority for the collection of this information is 35 U.S.C. 2(b)(2); (2) furnishing of the information solicited is voluntary; and (3) the principal purpose for which the information is used by the U.S. Patent and Trademark Office is to process and/or examine your submission related to a patent application or patent. If you do not furnish the requested information, the U.S. Patent and Trademark Office may not be able to process and/or examine your submission, which may result in termination of proceedings or abandonment of the application or expiration of the patent.

The information provided by you in this form will be subject to the following routine uses:

1. The information on this form will be treated confidentially to the extent allowed under the Freedom of Information Act (5 U.S.C. 552) and the Privacy Act (5 U.S.C. 552a). Records from this system of records may be disclosed to the Department of Justice to determine whether the Freedom of Information Act requires disclosure of these records.
2. A record from this system of records may be disclosed, as a routine use, in the course of presenting evidence to a court, magistrate, or administrative tribunal, including disclosures to opposing counsel in the course of settlement negotiations.
3. A record in this system of records may be disclosed, as a routine use, to a Member of Congress submitting a request involving an individual, to whom the record pertains, when the individual has requested assistance from the Member with respect to the subject matter of the record.
4. A record in this system of records may be disclosed, as a routine use, to a contractor of the Agency having need for the information in order to perform a contract. Recipients of information shall be required to comply with the requirements of the Privacy Act of 1974, as amended, pursuant to 5 U.S.C. 552a(m).
5. A record related to an International Application filed under the Patent Cooperation Treaty in this system of records may be disclosed, as a routine use, to the International Bureau of the World Intellectual Property Organization, pursuant to the Patent Cooperation Treaty.
6. A record in this system of records may be disclosed, as a routine use, to another federal agency for purposes of National Security review (35 U.S.C. 181) and for review pursuant to the Atomic Energy Act (42 U.S.C. 218(c)).
7. A record from this system of records may be disclosed, as a routine use, to the Administrator, General Services, or his/her designee, during an inspection of records conducted by GSA as part of that agency's responsibility to recommend improvements in records management practices and programs, under authority of 44 U.S.C. 2904 and 2906. Such disclosure shall be made in accordance with the GSA regulations governing inspection of records for this purpose, and any other relevant (i.e., GSA or Commerce) directive. Such disclosure shall not be used to make determinations about individuals.
8. A record from this system of records may be disclosed, as a routine use, to the public after either publication of the application pursuant to 35 U.S.C. 122(b) or issuance of a patent pursuant to 35 U.S.C. 151. Further, a record may be disclosed, subject to the limitations of 37 CFR 1.14, as a routine use, to the public if the record was filed in an application which became abandoned or in which the proceedings were terminated and which application is referenced by either a published application, an application open to public inspections or an issued patent.
9. A record from this system of records may be disclosed, as a routine use, to a Federal, State, or local law enforcement agency, if the USPTO becomes aware of a violation or potential violation of law or regulation.

APPLICATION FOR PATENT

INVENTORS:

5

PAUL F. REMBACH

GREG CASTLEMAN

TITLE:

10

SYSTEM FOR OPERATING A VESSEL

15

ATTORNEY DOCKET NO.: 1875.003

20

25

SPECIFICATION

CROSS REFERENCE TO RELATED APPLICATIONS

5 [0001] This application is a Continuation-in-Part of Co-pending US Patent Application Serial No. 12/313,732, filed on November 24, 2008, which claims the benefit of the filing date of US Provisional Patent Application Serial No. 61/004,397, filed November 25, 2007. The disclosures of these applications are incorporated herein by reference.

FIELD

10 [0002] The present embodiments relate to a system for operating a vessel.

BACKGROUND

[0003] A need exists for a system for operating a vessel that utilizes both AC power supplies, such as generators, and DC power supplies, such as battery banks.

15 [0004] A further need exists for a system for operating a vessel that can determine the most efficient power source to power the vessel and automatically draws power from the most efficient power source.

[0005] In addition a need exists for a system for operating a vessel that reduces carbon emissions and the cost of operating the vessel by reducing fuel consumption.

20 [0006] Furthermore, a system for operating a vessel that provides additional power sources in the event that contaminated fuel is taken aboard is needed.

[0007] The present embodiments meet these needs.

BRIEF DESCRIPTION OF THE DRAWINGS

[0008] The detailed description will be better understood in conjunction with the accompanying drawings as follows:

5 **[0009]** Figure 1 depicts a schematic of an illustrative power system having a power management system according to one or more embodiments.

[00010] Figure 2 depicts a schematic of the illustrative power management system of Figure 1 according to one or more embodiments.

[00011] Figure 3 depicts a schematic of a control and monitor system for a battery bank according to one or more embodiments.

10 **[00012]** Figure 4 depicts an illustrative embodiment of a master data storage according to one or more embodiments.

[00013] Figure 5 depicts an illustrative embodiment of a data storage device in communication with a slave processor according to one or more embodiments.

15 **[00014]** Figure 6 depicts a vessel having an illustrative power system disposed thereon according to one or more embodiments.

[00015] Figure 7 depicts the vessel of Figure 6 when the illustrative power system is in a stealth mode according to one or more embodiments.

20 **[00016]** Figure 8 depicts the vessel of Figure 6 when the illustrative power system is in a hybrid mode combining both AC power and DC power according to one or more embodiments.

[00017] Figure 9 depicts the vessel of Figure 6 when the power system is in a docked mode according to one or more embodiments.

[00018] Figure 10 depicts the vessel of Figure 6 when the power system is in a maintenance mode according to one or more embodiments.

[00019] The present embodiments are detailed below with reference to the listed Figures.

DETAILED DESCRIPTION OF THE EMBODIMENTS

5 [00020] Before explaining the present system in detail, it is to be understood that the system is not limited to the particular embodiments and that it can be practiced or carried out in various ways.

[00021] The present embodiments generally relate to a system for operating a vessel.

10 [00022] Operating the vessel can include managing certain aspects of the vessel. The aspects of the vessel can be the power system, propulsion system, and vessel service loads. The computer instructions can allow for automated management of a portion or all of the components of the vessel. The computer instructions can be used in conjunction with manual operation of one or more components of the vessel.

15 [00023] An illustrative system can also include a power management system in communication with the load and power sources. The power management system can include a processor. The processor can be a microprocessor or any other type of processor.

[00024] A data storage can be in communication with the processor. The data storage can be or include a hard drive, a virtual hard drive, a flash drive, or other computer readable medium.

20 [00025] The data storage can have a plurality of computer instructions stored thereon for performing one or more embodiments of the method described herein and as further explained below.

25 [00026] The power management system can control or instruct a control system. The control system can be an analog or digital control system. The control system can include hardware for operating or controlling the loads of the vessel, the power output of the

AC power source, and the battery banks.

- 5
- [00027]** The power management system can also include an operator interface to limit the total amount of power that can be utilized over a period of time. The operator interface can limit the amount of power that can be utilized over a period of time based on the power source reserves.
- [00028]** The system can be used to perform one or method of operating a vessel. The method can include determining the most efficient power source from a plurality of power sources for operating the vessel. The plurality of power sources can include one or more battery banks and one or more AC power sources.
- 10 **[00029]** Determining the most efficient power source from a plurality of power sources for operating the vessel can include monitoring the amount of power needed for all loads. The loads can include auxiliary equipment, such as winches, pumps, thrusters, hotel loads, and navigation equipment.
- 15 **[00030]** Determining the most efficient power source from a plurality of power sources can also include comparing the state of charge of the battery banks and comparing load curves of the AC power sources to the required load to optimize the carbon fuel intake of the engine. For example, if one or more engines of one of the AC power sources online are operating at more than 5 percent outside of its optimized load curve, the engine speed and generator voltage can be adjusted to bring the engine into an optimized operational state. The optimized load curve is supplied by the engine
- 20 manufacture based on carbon emission levels and fuel efficiency.
- [00031]** The battery banks can include one or more cells, and the AC power sources can include shore power, one or more generators, or combinations thereof.
- 25 **[00032]** In one or more embodiments, the battery cells within the battery banks can be maintained within a preset limit of one another. The preset limit can be when the state of charge of cells is within from about 3 percent to about 5 percent of one another. The balancing of the battery cells can include monitoring the voltage of each

individual cell and transporting energy from the highest charged cell to the lowest charged cell to equalize all cells. The energy can be transported by selectively opening or closing one or more electrical pathways.

5 [00033] The most efficient power source can be determined by comparing the actual load against the state of charge of the battery banks and the available power that can be supplied from the AC power sources.

10 [00034] The method can also include drawing power from the most efficient power source to operate the vessel. The drawing of power from the most efficient power source can be controlled by a power management system, such as illustrated below. In one or more embodiments, the power management system can control the voltage output from one or more AC power sources to provide the most efficient power source.

15 [00035] For example, the AC power output can be increased to prevent current flow from the battery banks, decreased such that power is drawn solely from one or more battery banks, or balanced with the available power in the battery bank such that the power is drawn from one or more AC power sources and one or more battery banks.

20 [00036] The method can also include harvesting energy from electrical rotating sources. The electrical rotating sources can include winches, pumps, thrusters, or combinations thereof. The harvested energy can be transferred back to the battery banks, used to power the vessel, or both. For example, if a thruster is slowed down or stopped, water introduces a negative torque onto the propeller that can be converted into electrical energy and provided back into the system. One or more inverters in communication with the battery bank can allow for bi-directional flow of the harvested energy. The power management system can monitor the direction of the electrical energy.

25 [00037] The method can include monitoring the battery bank. For example, the power management system can be in communication with one or more sensors that are acquiring data related to one or more battery banks. The sensors can include temperature sensors, such as resistive thermo devices; voltage sensors, such as volt meters; current sensors, such as amp meters; or other sensors.

5 [00038] Monitoring the battery bank can include communicating sensors with each cell; acquiring output voltage for all the cells and the voltage output of each cell, and acquiring current of the battery bank output; and the temperature of each cell. The state of charge of the individual cells and the battery bank can be determined using a manufacturer provided table that can be integrated with the power management system.

10 [00039] The method can also include charging the battery bank when the charge of the battery bank drops below a preset limit. The preset limit can be a state of charge of 10 percent, 20 percent, 30 percent, 40 percent, 50 percent, 60 percent, or 80 percent. The preset limit can be determined by the type of battery used and the manufacture specification. The battery banks can be charged by the harvested energy, one or more AC power sources, one or more external power source, or a combination thereof. The battery banks can be placed in a charge state when the AC powers sources are at an output greater than the stored potential power in the battery banks. For example, 15 when the battery banks reaches a preset limit, for example 50 percent charge, the AC output is increased thereby preventing energy draw from the battery bank and providing a portion of the AC power to the battery bank.

20 [00040] In one or more embodiments, the vessel can be operated by solely using the battery bank. This is an advantage because it eliminates noise associated with the operation of the vessel, reduces carbon emissions, and reduces costs associated with fuel consumption.

25 [00041] In one or more embodiments, the method can also include automatically switching to the AC power supply when the battery bank reaches the predetermined state of charge. Accordingly, the one or more AC power supplies can be used to operate the vessel when the battery bank reaches the predetermined state of charge and one or more battery banks can be recharged.

[00042] In one or more embodiments of the method, the vessel can be operated using power from two AC power sources, and the AC power sources can be automatically

synchronized with one another. The AC power sources can be synchronized with one another using the power management system. For example, the power management system can include computer instructions for controlling the engine speed for each of the AC power sources and controlling the voltage output of each of the generators, and computer instruction for ensuring synchronization of the sinusoidal output of each generator.

[00043] As the vessel is operated with one or more AC power sources, the state of charge of one or more battery banks can be managed. Accordingly the state of charge of the battery banks can be concurrently managed as the vessel is powered by one or more of the AC power sources.

[00044] In one or more embodiments of the method, the AC power source can be operated to provide a constant voltage. For example, the AC power source can be a generator system. The generator system can include an engine and a generator. Accordingly, the engine can be operated at a constant rotational speed, and the generator can provide a constant voltage. Accordingly, a constant power load can be maintained on the engine by controlling the rotational speed of the engine and the voltage from the generator. This can be used to allow for servicing and maintenance of the battery banks.

[00045] In one or more embodiments, the engine can be operated at a varying rotational speed and the generator can provide a variable voltage output.

[00046] Figure 1 depicts a schematic of an illustrative power system having a power management system according to one or more embodiments. The system 100 for operating a vessel can include a plurality of power sources for operating the vessel. The plurality of power sources can include one or more DC power sources (two DC powers sources are depicted as battery banks 110 and 115). The plurality of power sources can also include one or more AC power sources (two AC power sources are depicted as generator systems 120 and 122). The system 100 can also include a power management system 150.

[00047] The first battery bank 110 can include one or more cells (four are shown 111, 112,

113, and 114). The cells 111, 112, 113, 114 can be connected in parallel or series. The cells 111, 112, 113, 114 can be in communication with a first control and monitor system 170.

5 **[00048]** The second battery bank 115 can include one or more cells (four are shown 116, 117, 118, and 119). The cells 116, 117, 118, 119 can be connected in parallel or series. The cells 116, 117, 118, 119 can be in communication with a second control and monitor system 172.

10 **[00049]** The control and monitor systems 170 and 172 can be in communication with the power management system 150. An illustrative control and monitor system is described in more detail below.

15 **[00050]** The first generator system 120 can include a first engine 123, such as a diesel or natural gas engine. The first engine 123 can have a first throttle 124 in communication with the power management system 150. The first generator system 120 can also include a first electrical generator 125 that is driven by the first engine 123.

[00051] The second generator system 122 can include a second engine 127. The second engine 127 can have a second throttle 129 in communication with the power management system 150. The second generator system 126 can also include a second electrical generator 128 that is driven by the second engine 127.

20 **[00052]** The first electrical generator 125 can be in communication with the first battery bank 110 by a first AC to DC inverter 176. The second electrical generator 127 can be in communication with the second battery bank 115 by a second AC to DC inverter 178. The AC to DC inverters 176 and 178 can be passive or active. The AC to DC inverter can be any commercially available AC to DC inverter.

25 **[00053]** The power management system 150 can be in communication with the control and monitor systems 170 and 172 and the generator systems 120 and 126. The power management system 150 is described in more detail in Figure 2.

- [00054]** Turning now to Figures 1 and 2. Figure 2 depicts a schematic of the illustrative power management system 150 according to one or more embodiments. The power management system 150 can include a processor 210, a data storage 220, and a plurality of computer instructions 230.
- 5 **[00055]** The processor 210 can be a processor or a microprocessor. For example, the processor 210 can be a personal computer, an Intel processor, a PLC, or the like. The processor 210 can be in communication with the data storage 220.
- [00056]** The data storage 220 can be a hard drive, a virtual hard drive, a flash drive, or other computer readable medium.
- 10 **[00057]** The plurality of computer instructions can be stored on the data storage 220. The plurality of computer instructions can include computer instructions for monitoring the battery bank 232, computer instructions for determining the most efficient power source to power the vessel 234, computer instructions to determine when one or more of the battery banks are at a predetermined state of charge 238, computer instructions for controlling one or more AC power source 241, computer instructions for controlling auxiliary devices of the vessel 242, and computer instructions for transferring harvested energy from one or more electrical rotating source to the battery bank, auxiliary devices of the vessel, loads of the vessel, or combinations thereof 244, computer instructions for comparing the power needed for all loads against each individual power source 245, computer instructions for monitoring the amount of power needed for all loads 246, and computer instructions to transfer a portion of the power from one or more AC power source to one or more of the battery banks to increase the state of charge for one or more of the battery banks 247.
- 15
- 20
- [00058]** The computer instructions for monitoring the battery bank 232 can determine the state of charge of the battery banks using data from the control and monitor systems 170 and 172.
- 25
- [00059]** Computer instructions for determining the most efficient power source to power the vessel 234 can obtain information regarding the determined state of the battery banks.

Accordingly, the computer instructions for determining the most efficient power source to power the vessel 234 can determine the state of the AC power sources; determine the state of the actual loads needed to power the vessel.

5 [00060] Consequently, the information determined by the computer instructions for determining the most efficient power source to power the vessel 234 can be used to increase the efficiency of the power system by instructing the processor to increase the AC power output, decreasing the AC power output, or balancing the AC power output with the battery bank power output. For example, if the computer instructions for determining the most efficient power source to power the vessel 234 determines
10 that the most efficient power source is the battery banks 110 and 115, the computer instructions for determining the most efficient power source to power the vessel 234 can instruct the processor to adjust the generator systems 120 and 126, such that the vessel is only powered by the battery banks 110 and 115.

15 [00061] The computer instructions to determine when one or more of the battery banks are at a predetermined state of charge 238 can receive the determined state of charge from computer instructions for monitoring the battery bank 232 and compare the determined state of charge to a predetermined state of charge, which is provided by the manufacturer of the cells, and communicate this information to the computer instructions for determining the most efficient power source to power the vessel 234.
20 Then the computer instructions for determining the most efficient power source to power the vessel 234 can tell the processor 210 to prevent transfer of energy from the battery banks 110 and 115 and to provide power from one or more of the generator systems 120 and 126 to charge the battery banks 110 and 115 if the determined state of charge is less the predetermined state of charge. Alternatively, if the determined
25 state of charge is greater than the predetermined state of charge the computer instructions for determining the most efficient power source 234 can decrease the generator systems 120 and 126 power output to allow more power to be drawn from the battery banks 110 and 115.

[00062] The computer instructions to transfer a portion of the power from one or more AC

power source to one or more of the battery banks to increase the state of charge for one or more of the battery banks 247 can cooperate with the computer instructions to determine when one or more of the battery banks are at a predetermined state of charge 238 and the computer instructions for monitoring the battery bank 232 to
5 selectively instruct the processor 210 to form one or more electrical communication paths between the one or more of the battery banks 110 and 115 and one or more of the generator systems 120 and 126.

[00063] The computer instructions for controlling auxiliary devices of the vessel 242 can instruct the processor to initiate the operation of one or more pumps, one or more
10 winches, or other auxiliary devices needed for critical operations on the vessel.

[00064] The computer instructions for transferring harvested energy from one or more electrical rotating source to the battery bank, auxiliary devices of the vessel, loads of the vessel, or combinations thereof 244 can determine the allowable amount of harvested energy that can be transferred back into the system and processor 210 can
15 selectively open one or more current paths to allow the harvested energy to be transferred back into the system.

[00065] The computer instructions for comparing the power needed for all loads against each individual power source 245 can cooperate with the computer instructions for monitoring the amount of power needed for all loads 246 to sum or calculate all the
20 power requirements of the vessel. The computer instructions for monitoring the amount of power needed for all loads 246 can instruct the processor to receive signals from one or more monitoring systems in communication with various components of the vessel to determine the required load. For example, the vessel can have one or more monitoring systems for monitoring service loads, and auxiliary device loads to
25 determine the total load required.

[00066] Figure 3 depicts a schematic of a control and monitor system for a battery bank according to one or more embodiments.

[00067] The control and monitor system 300 can include a master battery monitoring

processor 314. The master battery monitoring processor 314 can be a microprocessor, an Intel processor, PLC, or the like.

[00068] The master battery monitoring processor 314 can be in communication with a master data storage 316. The master data storage 316 is described in more detail in Figure 4.

5 **[00069]** The master battery monitoring processor 314 can be in communication with a voltage sensor 311. Other sensors can also be in direct communication with the master battery monitoring processor 314. The voltage sensor 311 can measure the power output of a battery bank 310.

10 **[00070]** The battery bank 310 can have one or more cells (four are shown 330, 332, 334, and 336). The cells can be any power cell such a lithium ion cells, acid based cells, or other commercially available cells.

15 **[00071]** The master battery monitoring processor 314 can be in communication with a plurality of slave processors 320, 322, 324, and 326. The first slave processor 320 can be in communication with a first cell 330. The second slave processor 322 can be in communication with a second cell 332. The third slave processor 324 can be in communication with a third cell 334. The fourth slave processor 326 can be in communication with a fourth cell 336.

20 **[00072]** The control and monitor system 300 can also include a plurality of sets of sensors 340, 342, 344, and 346. Each set of sensors 340, 342, 344, and 346 can be or include a voltage sensor, a temperature sensor, a current sensor, and other relevant sensors.

25 **[00073]** The first set of sensors 340 can be in communication with the first cell 330 and the first slave processor 320. The second set of sensors 342 can be in communication with the second cell 332 and the second slave processor 322. The third set of sensors 344 can be in communication with the third cell 334 and the third slave processor 324. The fourth set of sensors 346 can be in communication with the fourth cell 336 and the fourth slave processor 326.

5
[00074] The slave processors 320, 322, 324, and 326 can acquire data from the associated set of sensors 340, 342, 344, and 346. The slave processors 320, 322, 324, and 326 can provide the acquired data to the master battery monitoring processor 314. The master battery monitoring processor 314 can communicate the acquired data to the power management system.

10
[00075] The slave processors 320, 322, 324, and 326 can be in independent communication with a plurality of data storage devices 380. For clarity only one data storage device is depicted; however, similar data storage devices can be in communication with the other slave processors 320, 322, 324, and 326. The data storage device 380 is described in more detail in Figure 5.

15
[00076] Figure 4 depicts an illustrative embodiment of the master data source according to one or more embodiments. The master data storage 316 can have computer instructions 370 for balancing the cells 330, 332, 334, and 336. For example, the computer instructions 370 can maintaining each cell 330, 332, 334, and 336 within a preset limit of one another by instructing the master battery monitoring processor 314 to selectively open and close electrical communication paths between the cells 330, 332, 334, and 336 to allow for transfer of energy from higher charged cells to lower charged cells. The master data storage 316 can also include computer instructions 370 for sounding an alert if one or more of the cells 330, 332, 334, and 336 are out of balance.
20

25
[00077] Figure 5 depicts an illustrative embodiment of the data storage devices in communication with the slave processors according to one or more embodiments. The data storage device 380 can include computer instructions for acquiring data from the plurality of sensors 390 and computer instruction 392 for determining the voltage of the associated cell.

[00078] Figure 6 depicts a vessel having an illustrative power system disposed thereon according to one or more embodiments.

[00079] The power system can be disposed on a vessel 400. The vessel 400 can be a barge,

tug boat, tanker, or other vessel. The power system can be similar to any one described herein. Accordingly, the power system can include a power management system 420, one or more AC power sources 430, and one or more DC power sources 440.

5 **[00080]** The power management system 420 can have a processor 422 in communication with one or more controllers for operating the vessel or critical elements of the vessel. For example, the processor 422 can be in communication with a first controller 423 for controlling the AC power source 430, a control and monitor system 442 for monitoring the DC power source 440. The power system can also include one or
10 more auxiliary controllers for controlling one or more auxiliary devices, such as auxiliary device 498.

[00081] The AC power source 430 can be connected to a DC bus 490 by an AC to DC converter 492. The AC to DC can also be referred to as an AC to DC inverter. The AC to DC converter 492 can be any commercially available AC to DC converter.

15 **[00082]** The DC power source can be connected to the DC bus 490. The DC bus 490 can also be connected to a DC to AC inverter 493. The DC to AC inverter 493 can be bi-directionally connected to the DC bus 490. The DC bus 490 can be a commercially available DC bus and can have internal control systems.

[00083] In one or more embodiments the DC to AC inverter 495 can be connected or in
20 communication with one or more auxiliary devices 498. The DC to AC inverter 495 can transfer harvested energy from the auxiliary device 498, such as an azimuth thruster, to the load or the DC power source 440. For example, the processor 422 can tell the DC to AC inverter 493 how much harvested energy can be transferred into the system, and the DC to AC inverter 493 can be selectively operated to allow energy
25 harvested from the electrical rotating source of the auxiliary device 498 or other auxiliary devices to be transferred back to the DC power source 440, the load 497, or both. Illustrative DC to AC inverters can include those available from Siemens, such as Sinamics inverters; or other commercially available DC to AC inverter. The DC to

AC 493 inverter can be bi-directionally connected to the connection auxiliary device 498, the load 497, and the DC bus 490.

5 [00084] The power system 410 can have a connection 460 for connecting to one or more external power sources (one external power source is depicted as shore power 499). The connection 460 can be in communication with the DC to AC inverter 493.

[00085] The processor 422 can be in communication with the first controller 423, the DC to AC inverter, the auxiliary device 498, and other components of the vessel 400.

[00086] Figure 7 depicts the vessel of Figure 6 when the illustrative power system is in a stealth mode according to one or more embodiments.

10 [00087] The power management system 420 can tell the first controller 423 to shut down the AC power source 430. Accordingly, the DC power source 440 can provide electricity to the loads required to operate the vessel 400.

15 [00088] Figure 8 depicts the vessel of Figure 6 when the illustrative power system is in a hybrid mode combining both AC power and DC power according to one or more embodiments.

[00089] The power management system 420 can adjust the first controller 423 to adjust the power output of the AC power source 430. Accordingly, the AC power source 430 can be accelerated to increase the power output therefrom, allowing the AC power source 430 to provide power for the entire load required to operate the vessel 400. Furthermore, some of the power outputted from the AC power source 430 can be used to charge the DC power source 440.

[00090] In addition, energy harvested from the auxiliary device 498 can be used to power some of the load or to charge the DC power source 440.

25 [00091] In addition, in this mode the processor 422 can selectively instruct the first controller 423 to manipulate the AC power source 430 such that the power output from the AC power source is balanced with the DC power source 440 to allow for both the AC

power source and the DC power source 440 to power the critical components of the vessel.

[00092] Figure 9 depicts the vessel of Figure 6 when the power system is in a docked mode according to one or more embodiments.

5 **[00093]** The AC power source 430 and the DC power source 440 can be prevented from outputting power, and shore power 499 can be communicated with the connection 460 to provide power to all the loads required to operate the vessel and to charge the DC power supply 440.

10 **[00094]** Figure 10 depicts the vessel of Figure 6 when the power system is in a maintenance mode according to one or more embodiments. In this mode the AC power source 430 can be excited preventing current from discharging from the DC power source 440, and the AC power source 430 can power all the loads required to operate the vessel. In one or more embodiments, a circuit breaker (not shown) can be used to remove the DC power supply 440 from the power system.

15 **[00095]** While these embodiments have been described with emphasis on the embodiments, it should be understood that within the scope of the appended claims, the embodiments might be practiced other than as specifically described herein.

CLAIMS

What is claimed is:

1. A system for operating a vessel, wherein the system comprises:
 - 5 a. a plurality of power sources for operating the vessel, wherein the power sources include a battery bank and an AC power source;
 - b. an auxiliary device disposed on the vessel, wherein the auxiliary device comprises an electrical rotating source, and wherein energy harvested from the electrical rotating source is transferred to the DC power source, a load of the vessel, or both; and
 - 10 c. a power management system comprising:
 - (i) a processor;
 - (ii) a data storage in communication with the processor; and
 - (iii) a plurality of computer instructions stored on the data storage, wherein the computer instructions comprise:
 - 15 1. computer instructions for monitoring the battery bank;
 2. computer instructions for determining the most efficient power source to power the vessel;
 - 20 3. computer instructions for controlling the AC power source to allow transfer of power solely from the battery bank to power the vessel, transfer of power solely from the AC power source to power the vessel; or transfer of power from both the AC power source and the battery bank to power the vessel;
 4. computer instructions to determine when the battery bank is at a predetermined level;

5. computer instructions for controlling auxiliary devices of the vessel;
and
 6. computer instruction for transferring harvested energy from the electrical rotating source to the battery bank, auxiliary equipment of the vessel, or combinations thereof.
- 5
2. The system of claim 1, wherein the battery bank comprises a plurality of battery cells.
 3. The system of claim 2, further comprising a master battery monitoring processor in communication with a plurality of slave processors, wherein each cell is in independent communication with one of the slave processors.
 - 10 4. The system of claim 3, further comprising a plurality of sensors in communication with the slave processors and each cell of the battery bank.
 5. The system of claim 4, wherein the slave processors are each in communication with a plurality of data storage devices, and wherein the data storage devices comprise computer instructions for acquiring data from the plurality of sensors and for determining the voltage of each cell.
 - 15 6. The system of claim 5, wherein the master processor is in communication with a master data storage, and wherein the master data storage comprises computer instructions for maintaining each cell within the battery bank within a preset limit of one another and computer instructions for sounding an alert if one or more of the cells is out of balance.
 - 20 7. The system of claim 6, wherein the master processor is in communication with the power management system.
 8. The system of claim 1, further comprising a connection for connecting to an external power source.
 9. The system of claim 8, wherein the external power source is shore power.
 - 25 10. A system for operating a vessel, wherein the system comprises:

- a. an AC power source;
- b. an AC to DC inverter connected to the AC power source;
- c. a DC power source in communication with the AC to DC inverter;
- d. a DC to AC inverter in communication with the AC to DC inverter and the DC power source; and
- e. a power management system comprising:
 - (i) a processor;
 - (ii) a data storage in communication with the processor; and
 - (iii) a plurality of computer instructions stored on the data storage, wherein the computer instructions comprise:
 - 1. computer instructions for monitoring the battery bank;
 - 2. computer instructions for determining the most efficient power source to power the vessel;
 - 3. computer instructions for controlling the AC power source to allow transfer of power solely from the battery bank to power the vessel, transfer of power solely from the AC power source to power the vessel; or transfer of power from both the AC power source and the battery bank to power the vessel;
 - 4. computer instructions to determine when the battery bank is at a predetermined level; and
 - 5. computer instructions for controlling auxiliary devices of the vessel.

11. The system of claim 10, wherein the battery bank comprises a plurality of battery cells.

12. The system of claim 11, further comprising a master battery monitoring processor in communication with a plurality of slave processors, wherein each cell is independent communication with one of the slave processors.
13. The system of claim 12, further comprising a plurality of sensors in communication with the slave processors and each cell of the battery bank.
14. The system of claim 13, wherein the slave processors are each in communication with a plurality of data storage devices, and wherein the data storage devices comprise computer instructions for acquiring data from the plurality of sensors and for determining the voltage of each cell.
15. The system of claim 14, wherein the master processor is in communication with a master data storage, and wherein the master data storage comprises computer instructions for maintaining each cell within the battery bank within a preset limit of one another, and computer instructions for sounding an alert if one or more of the cells is out of balance.
16. The system of claim 15, wherein the master processor is in communication with the power management system.
17. The system of claim 10, further comprising a connection for connecting to an external power source.
18. The system of claim 17, wherein the external power source is shore power.
19. A system for operating a vessel, wherein the system comprises:
 - a. an AC power source;
 - b. an AC to DC inverter connected to the AC power source;
 - c. a DC power source in communication with the AC to DC inverter;
 - d. a DC to AC inverter in communication with the AC to DC inverter and the DC power source; and

- e. a power management system comprising:
 - (i) a processor;
 - (ii) a data storage in communication with the processor; and
 - (iii) a plurality of computer instructions stored on the data storage, wherein the computer instructions comprise:
 - 1. computer instructions for monitoring the battery bank;
 - 2. computer instructions for determining the most efficient power source to power the vessel;
 - 3. computer instructions for controlling the AC power source to allow transfer of power solely from the battery bank to power the vessel, transfer of power solely from the AC power source to power the vessel; or transfer of power from both the AC power source and the battery bank to power the vessel;
 - 4. computer instructions to determine when the battery bank is at a predetermined level;
 - 5. computer instruction to transfer a portion of the power from the AC power source to the battery bank to increase the state of charge of the battery bank; and
 - 6. computer instructions for controlling auxiliary devices of the vessel.

ABSTRACT OF DISCLOSURE

One or more embodiments of a system for operating a vessel is provided herein. An illustrative system can include a plurality of power sources for operating the vessel. The power sources can include a battery bank and an AC power source. The system can also include an auxiliary device
5 disposed on the vessel, wherein the auxiliary device comprises an electrical rotating source. Energy can be harvested from the electrical rotating source and transferred to the DC power source, a load of the vessel, or both. The illustrative system can also include a power management system that can include a processor; a data storage in communication with the processor; and a plurality of computer instructions stored on the data storage.

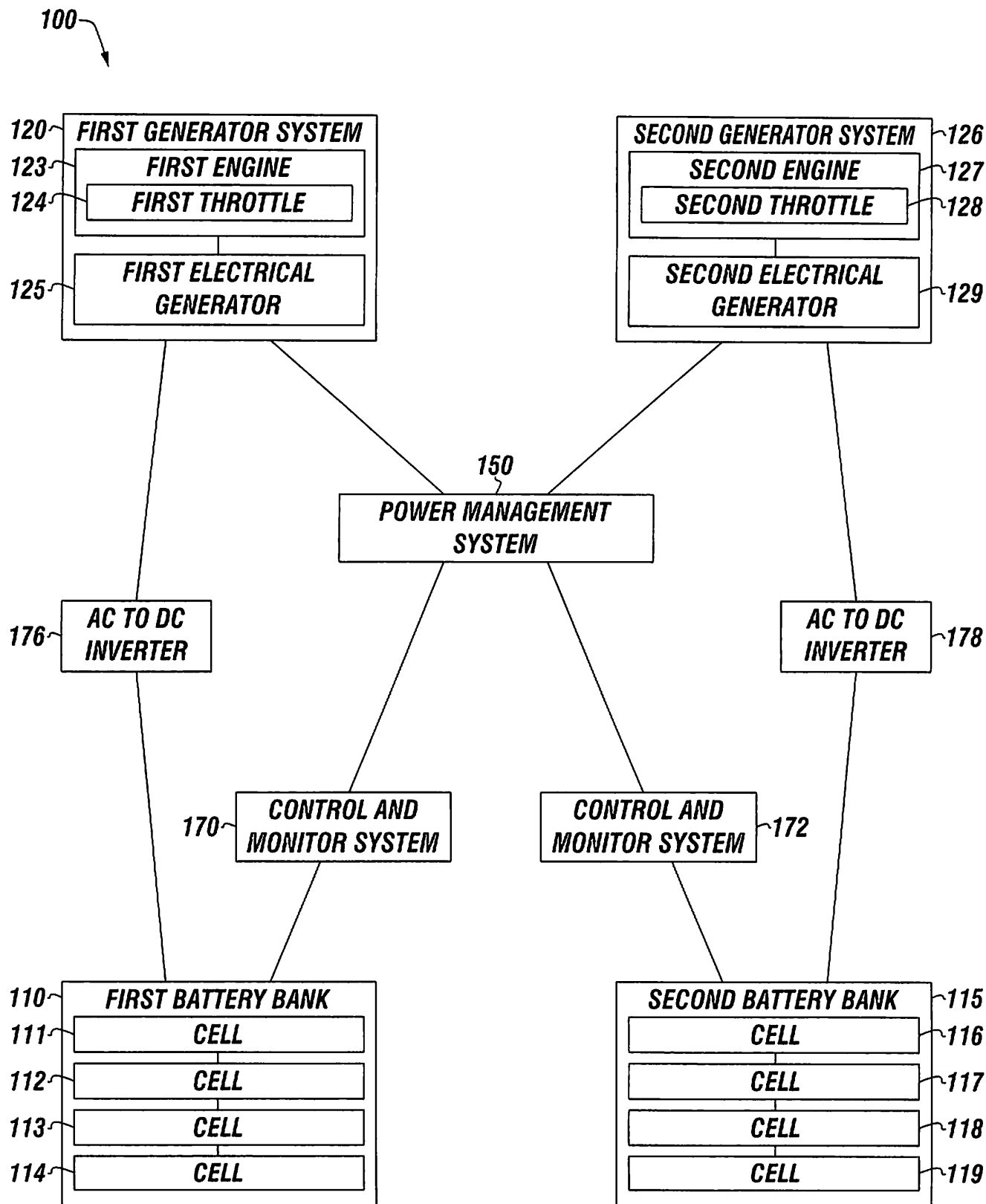

FIGURE 1

150

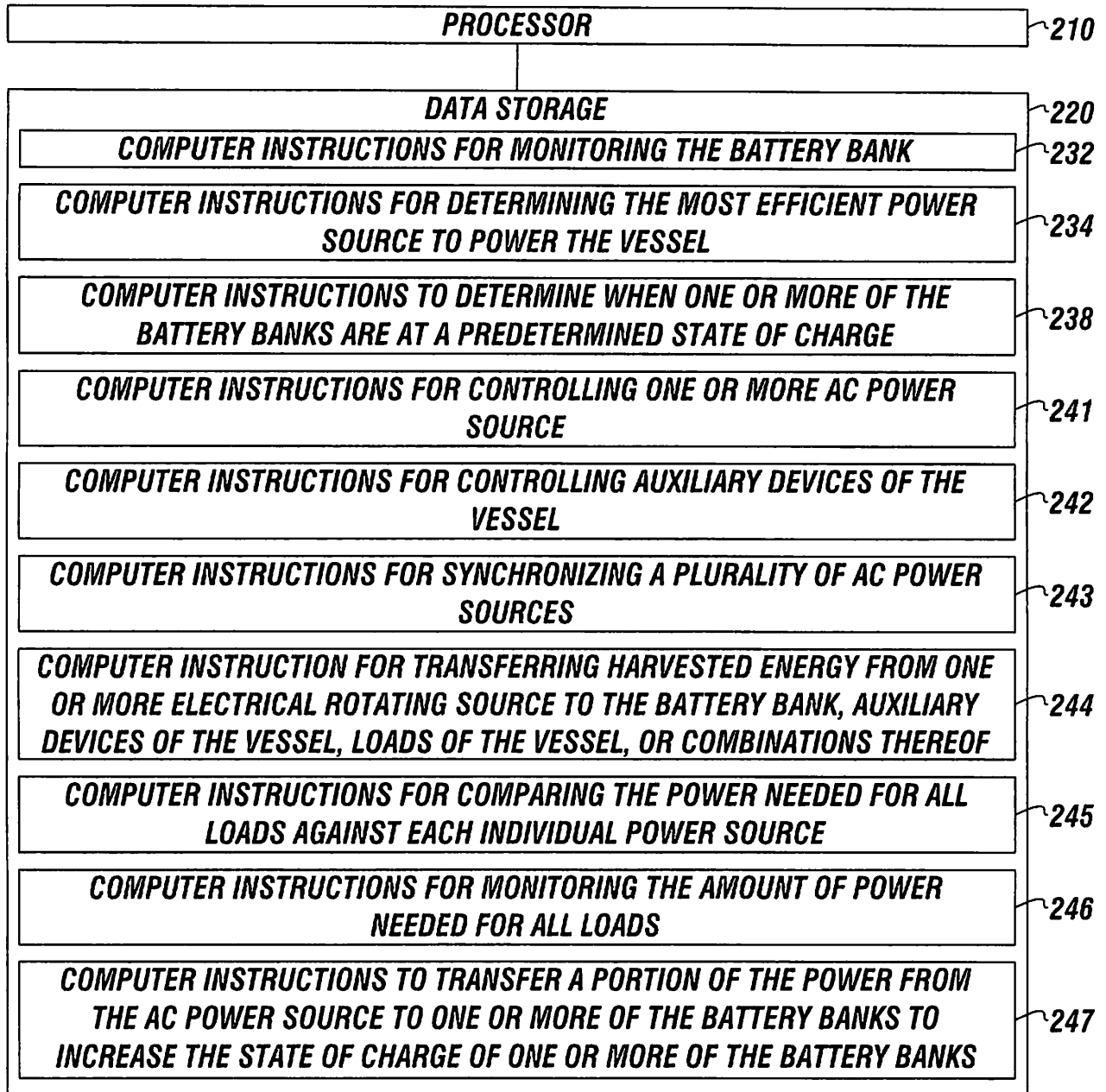

FIGURE 2

FIGURE 3

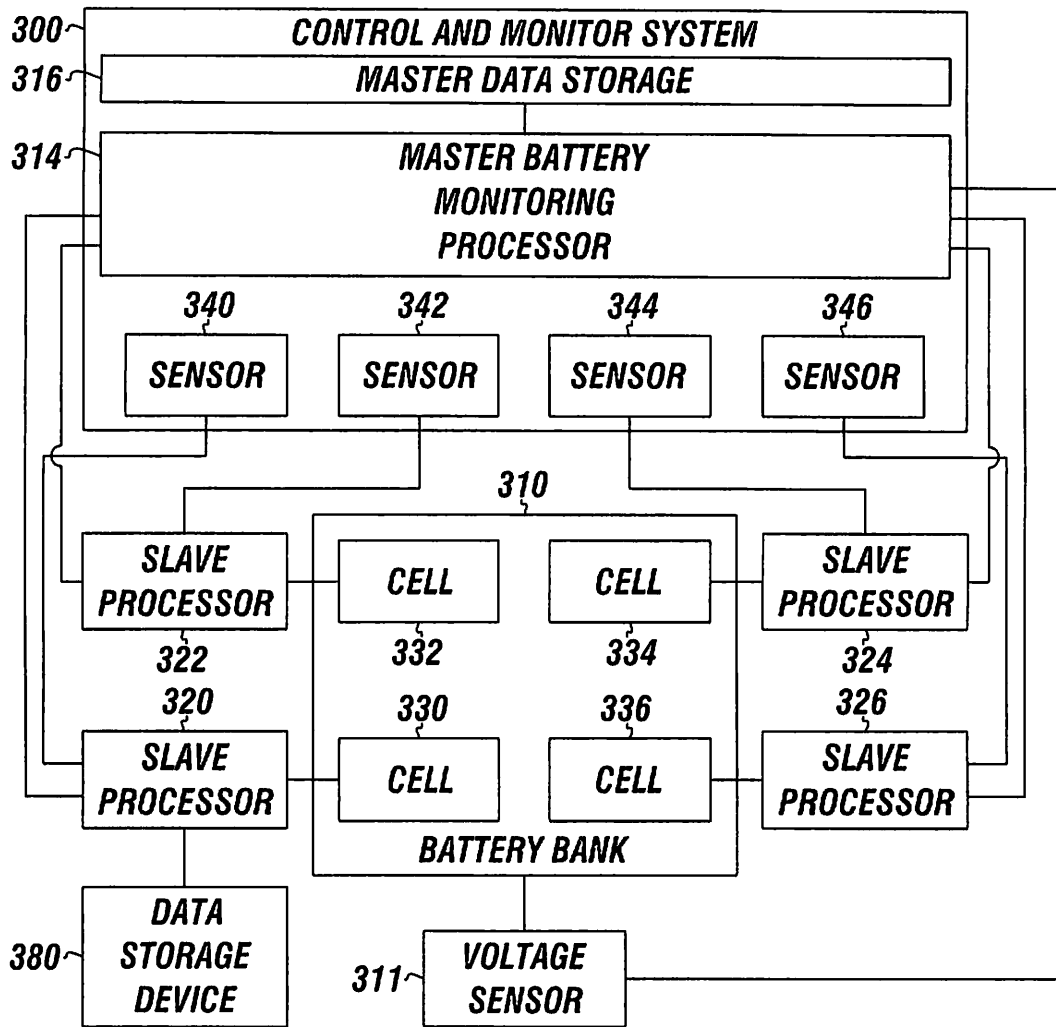

FIGURE 4

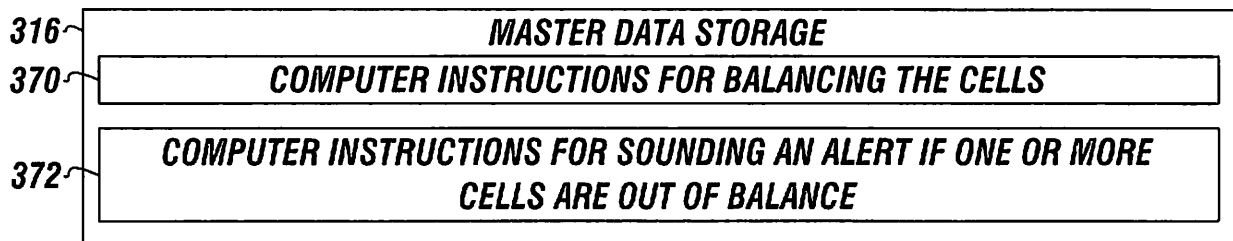
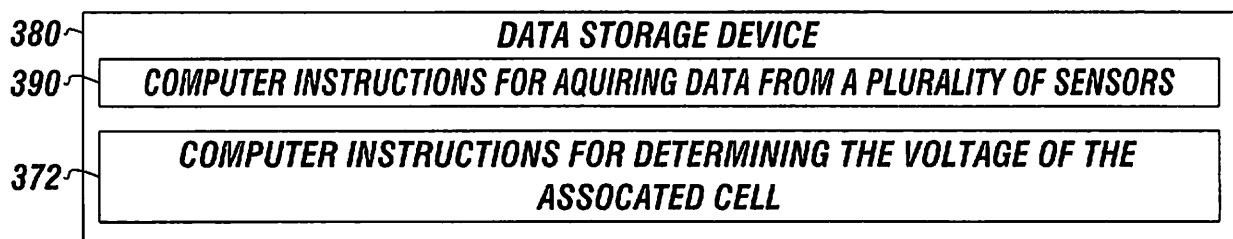

FIGURE 5



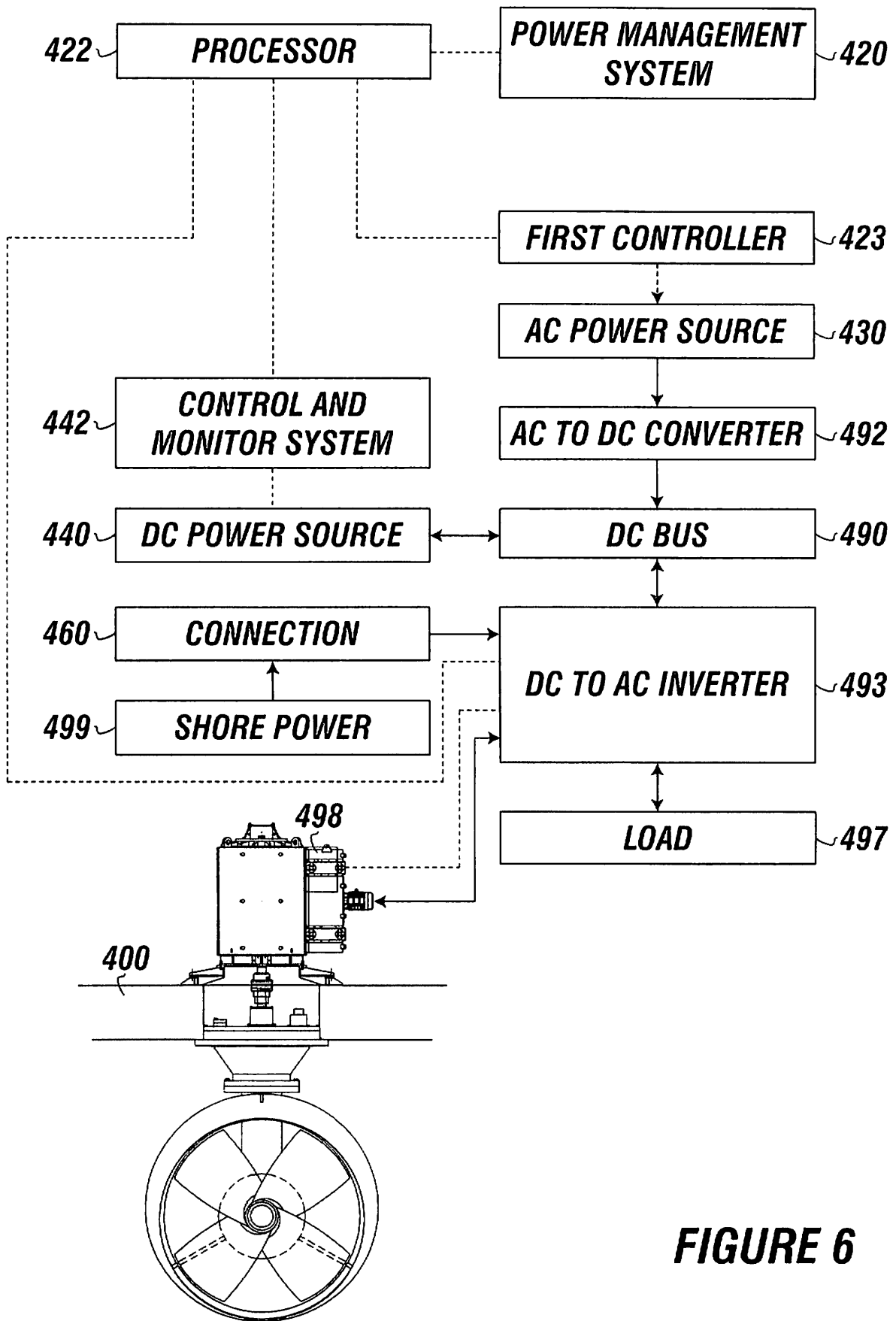

FIGURE 6

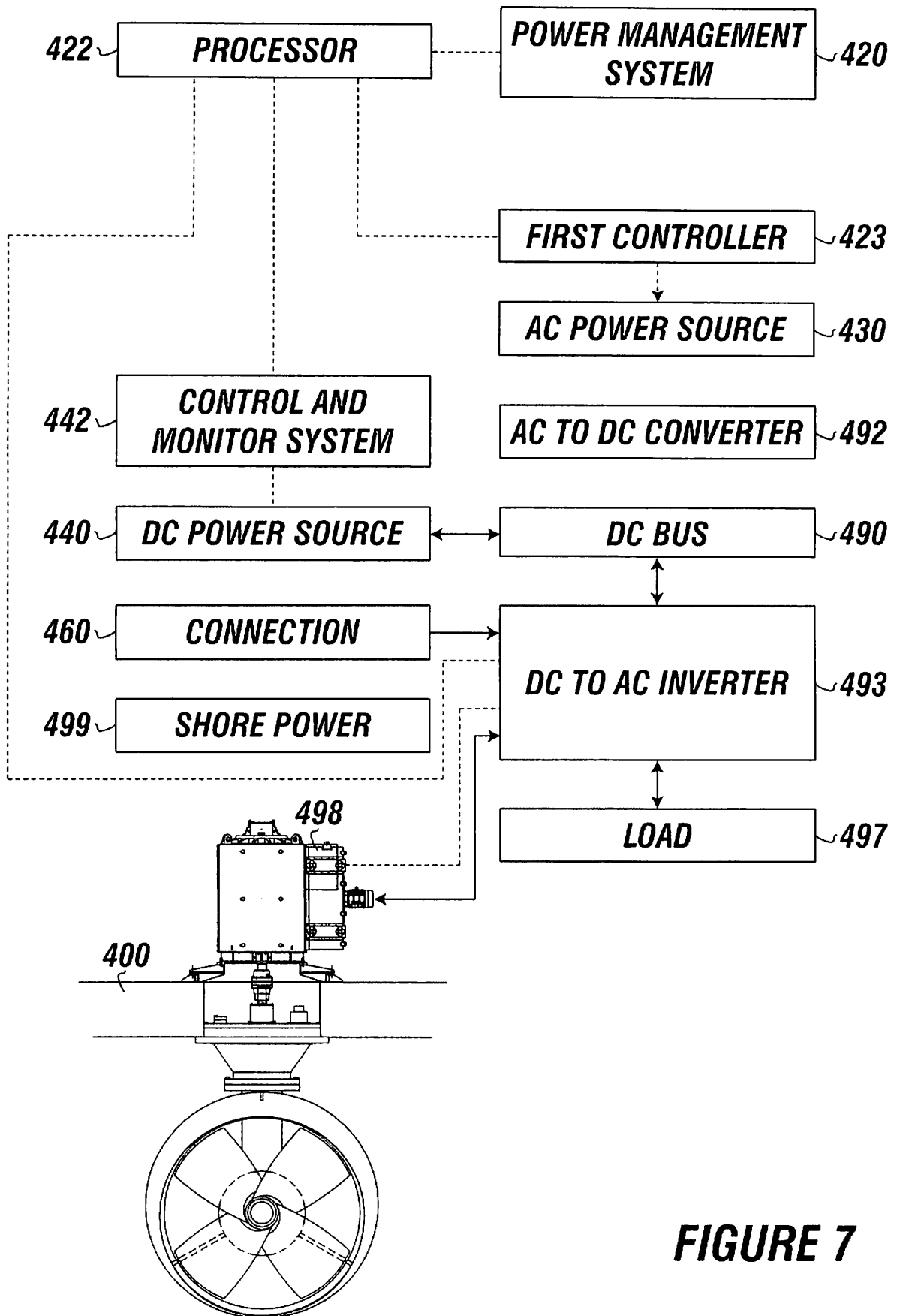

FIGURE 7

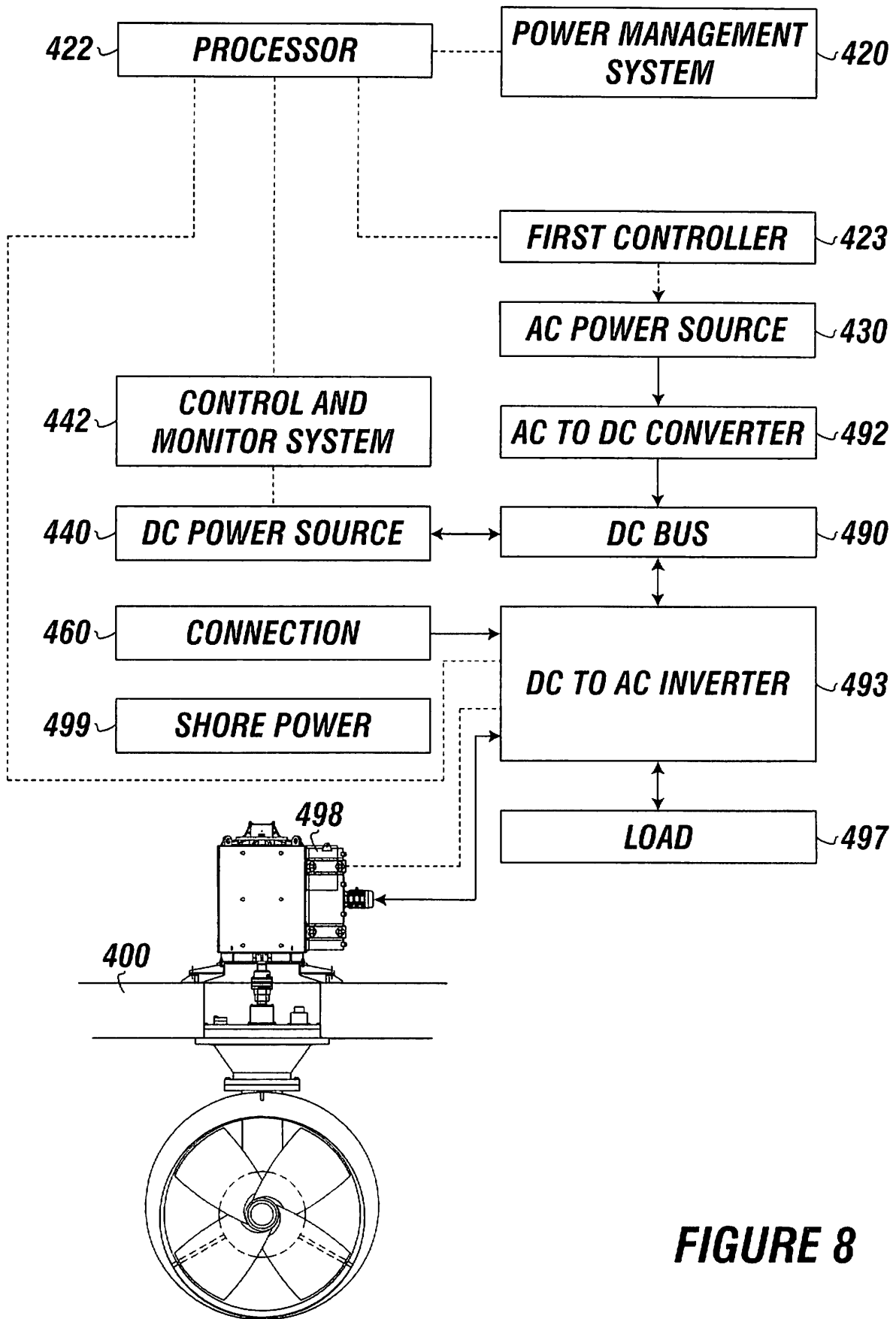

FIGURE 8

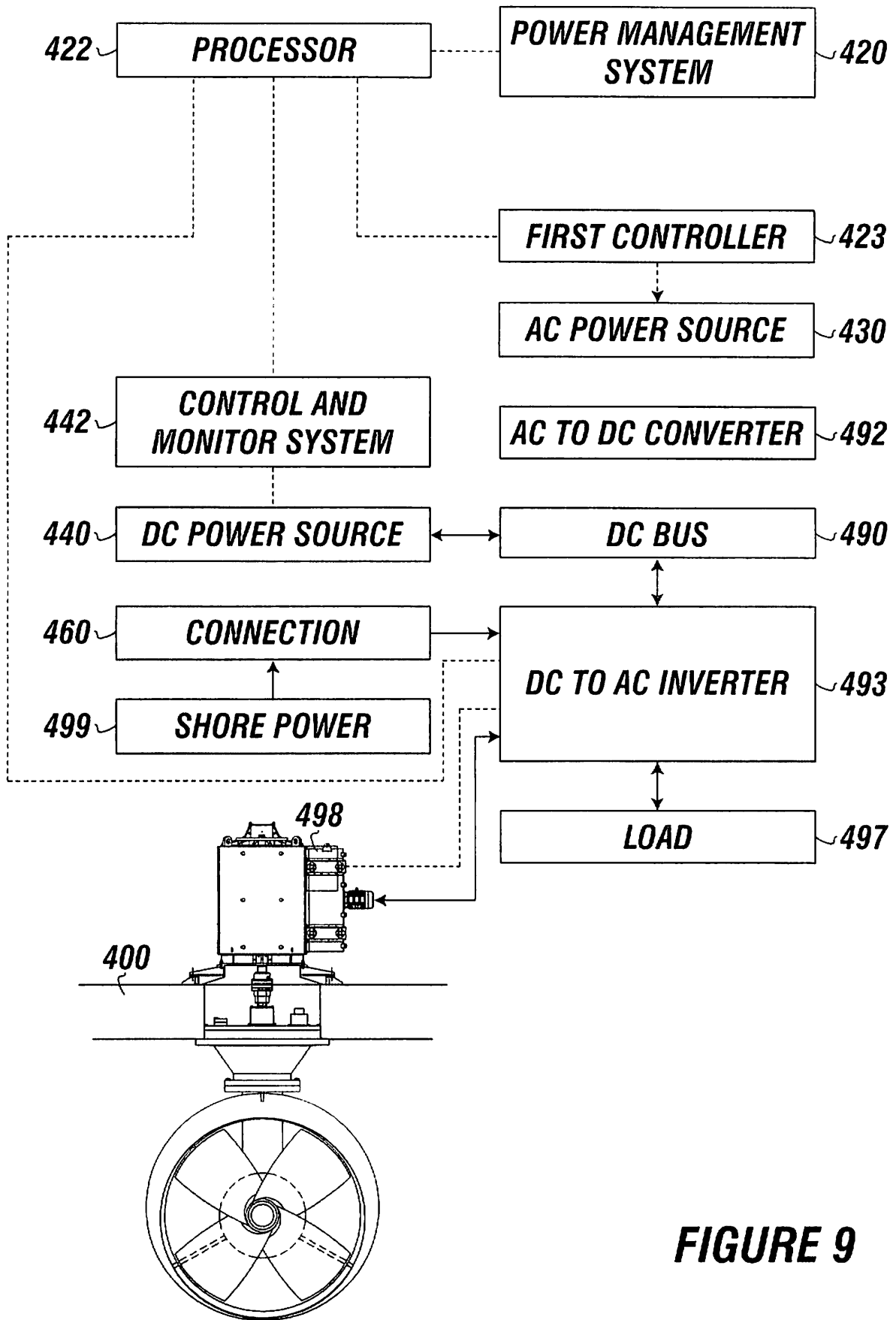

FIGURE 9

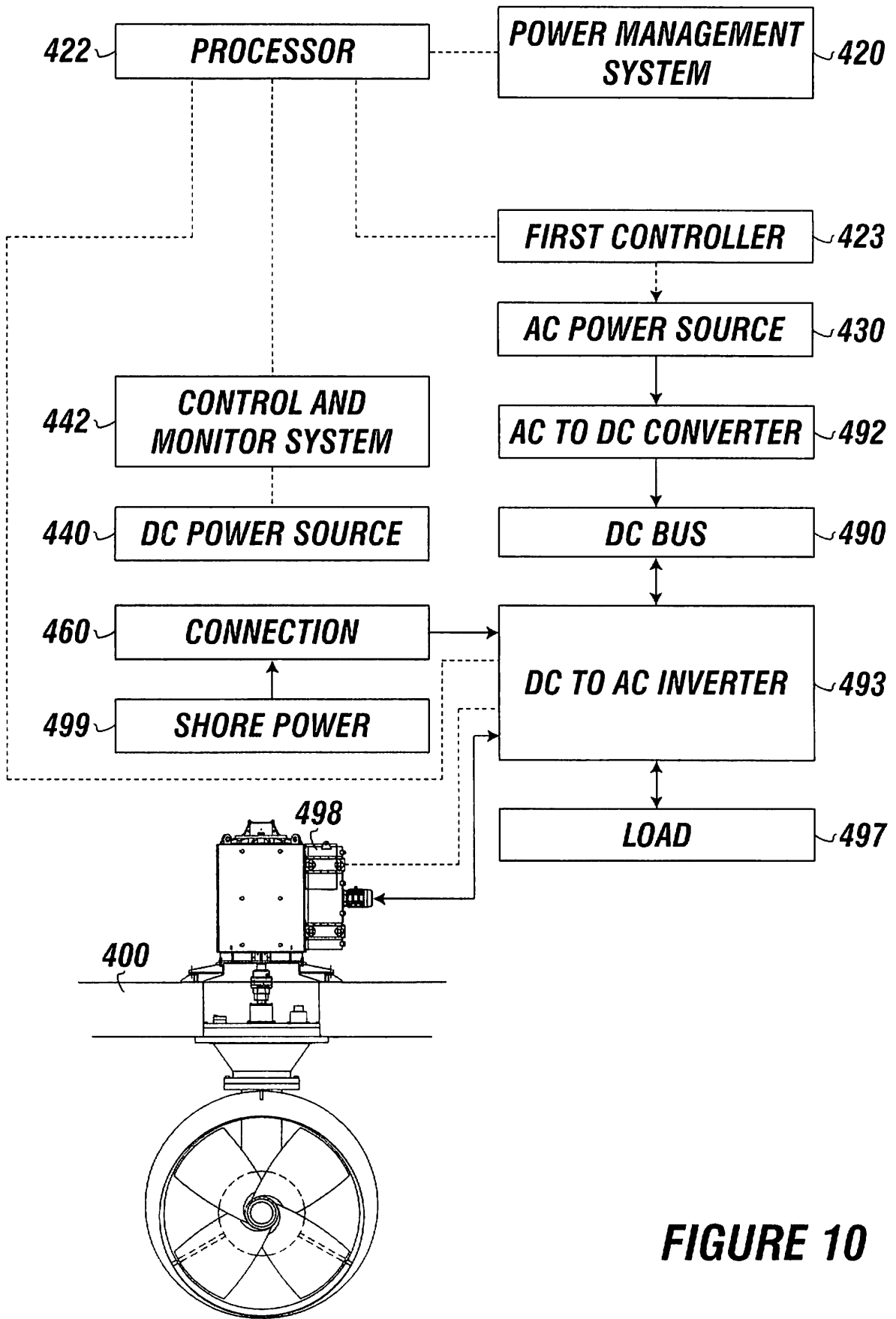

FIGURE 10